

Description

Magnecraft Power Relays

92

DPST-NO, 30 A;

DPDT, 30 A (NO) / 3 A (NC)



92S7A22D-24

Description

The 92 series power relays offer a small package size and features Class F insulation for a maximum coil temperature of 155 °C (311 °F). These power relays meet UL508 spacing and are directly DIN or panel mountable.

Feature	Benefit
Standard Class F insulation	Allows for maximum coil temperature of 155 °C (311 °F) which is ideal for elevated temperature applications
DIN and panel mount cover	Mounts directly onto DIN rail or panel and provides flexibility to accommodate last minute design changes
Sealed construction, vented	To resist dust and debris in harsh environments

Rated Contact Current	Contact Configuration	Coil Voltage	Coil Resistance (Ω)	Standard Part Number
30 A	DPST-NO	24 Vac	170 ¹	92S7A22D-24
		120 Vac	4250 ¹	92S7A22D-120
		240 Vac	16500 ¹	92S7A22D-240
		12 Vdc	86	92S7D22D-12
		24 Vdc	350	92S7D22D-24
30 A (NO) / 3 A (NC)	DPDT	24 Vac	170 ¹	92S11A22D-24
		120 Vac	4250 ¹	92S11A22D-120
		240 Vac	16500 ¹	92S11A22D-240
		12 Vdc	86	92S11D22D-12
		24 Vdc	350	92S11D22D-24

¹ All AC coils are rectified.

Part Number Explanation

Series: **92** **S** **7** **A** **22D** - **24**

92

Cover:
S = Dust cover

Contact Configuration:

7 = DPST-NO
11 = DPDT

Coil Type:

A = AC
D = DC

Mounting Style:

22D = DIN rail and panel mount cover

Coil Voltage:

12 = 12 V 120 = 120 V
24 = 24 V 240 = 240 V

Note: Available coil voltages include 12 Vdc, 24 Vac, 24 Vdc, 120 Vac, and 240 Vac.

Magnecraft Power Relays

92

DPST-NO, 30 A;

DPDT, 30 A (NO) / 3 A (NC)

Specifications

Part Number	92S7	92S11
Contact Characteristics		
Contact Configuration	DPST-NO	DPDT
Contact Material	Silver Alloy	
Thermal (Carrying) Current	30 A	30 A (NO); 3 A (NC)
Maximum Switching Voltage (Conforming to IEC)	250 Vac / 28 Vdc	
Maximum Switching Voltage (Conforming to UL)	300 Vac / 28 Vdc	
Current Ratings at Voltage (Conforming to IEC)	(NO) 30 A at 250 Vac; 25 A at 28 Vdc, 100,000 cycles	(NO) 30 A at 250 Vac; 25 A at 28 Vdc, 100,000 cycles (NC) 3 A at 250 Vac; 3 A at 28 Vdc, 100,000 cycles
Current Ratings at Voltage (Conforming to UL)	(NO) General Use: 30 A at 277 Vac, 100,000 cycles Resistive: 20 A at 28 Vdc, 100,000 cycles Motor: 1.0 hp at 120 Vac; 3.0 hp at 240 Vac, 100,000 cycles LRA/FLA : 96 A / 22 A @ 240 Vac (AC coil), 30,000 cycles; 110 A / 25.3 A @ 240 Vac (DC coil), 30,000 cycles Pilot Duty: 720 VA / A300, 6,000 cycles Short Circuit: 5000 Arms @ 240 Vac Tungsten: 10 A at 120 Vac 50/60 Hz, 25,000 cycles; 6 A at 250 Vac 50/60 Hz, 25,000 cycles	(NO) General Use: 30 A at 277 Vac, 100,000 cycles Resistive: 20 A at 28 Vdc, 100,000 cycles Motor: 1.0 hp at 120 Vac; 3.0 hp at 240 Vac, 100,000 cycles LRA/FLA : 96 A / 22 A @ 240 Vac (AC coil), 30,000 cycles; 110 A / 25.3 A @ 240 Vac (DC coil), 30,000 cycles Pilot Duty: 720 VA / A300, 6,000 cycles Short Circuit: 5000 Arms @ 240 Vac Tungsten: 10 A at 120 Vac 50/60 Hz, 25,000 cycles; 6 A at 250 Vac 50/60 Hz, 25,000 cycles (NC) Resistive: 3 A at 277 Vac 6,000 cycles; 3 A at 28 Vdc 100,000 cycles
Switching capacity	Maximum: 7500 VA / 840 W (when mounted with 13 mm gap between 2 relays); 6250 VA / 700 W (when mounted side by side without a gap) Minimum: 170 mW	
Minimum Switching Requirements.	10 mA at 17 V	
Coil Characteristics		
Coil Voltage Range ¹	12–240 Vac ² 50/60 Hz; 12–24 Vdc	
Operating Range (% of Nominal)	80%–110%	
Average Consumption	4 VA -20%/+10% (AC); 1.7 W -20%/+10% (DC)	
Drop-out Voltage Threshold	15% minimum (AC); 10% minimum (DC)	
General Characteristics		
Electrical Life at Rated Load	Resistive load: 100,000 cycles, unless otherwise specified under “Current Ratings at Voltage” Inductive load: See load curves on page 25.	
Mechanical Life at No Load (Unpowered)	5,000,000 operations	
Operate Time (Response Time) at Nominal Coil Voltage	25 ms maximum	
Rated Impulse Withstand	4000 V (1.2 μs / 50 μs)	
Dielectric Strength	Between coil and contact: 4000 Vac Between poles: 2000 Vac Between contacts: 1500 Vac	
Operating Temperature Range	-40 – +55 °C (-40 – +131 °F)	
Storage Temperature Range	-40 – +85 °C (-40 – +185 °F)	
Vibration Resistance	+/- 1 mm (10–35 Hz) and 3 g-n (35–150 Hz)	
Shock Resistance	10 g-n (in operation) / 30 g-n (not in operation)	
Weight (Average)	0.082 kg (0.181 oz)	
Conformity to Standards	IEC/EN 61810-1, UL 508, CSA C22-2 n°14	
Product Certifications and Standards	UL Listed (E48539), CSA (2582574), CE, RoHS	

Note: Actual product performance may vary depending on application and environmental conditions.

¹ For available standard coil voltages, please refer to the standard part number table on page 23.

² All AC coils are rectified.

Magnecraft Power Relays

92
DPST-NO, 30 A;
DPDT, 30 A (NO) / 3 A (NC)

Specifications (continued)

Electrical durability of contacts, IEC ratings		
Resistive load	AC reduction coefficient for inductive load (depending on power factor $\cos \varphi$) Durability (inductive load) = durability (resistive load) x reduction coefficient.	Maximum switching capacity on DC resistive load

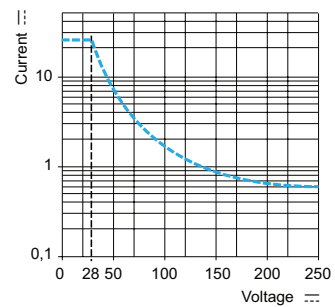
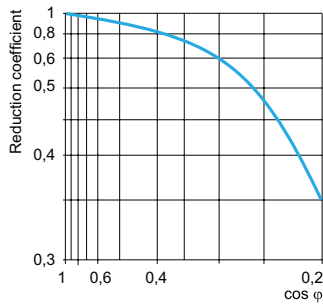
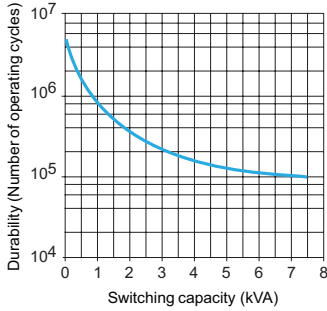

Note: These curves are for reference only and are typical values only. Actual performance is dependant upon the actual load, environment, duty cycle, and other conditions specific to the application.

Dimensions — inches (millimeters)

DPST-NO (2 NO):

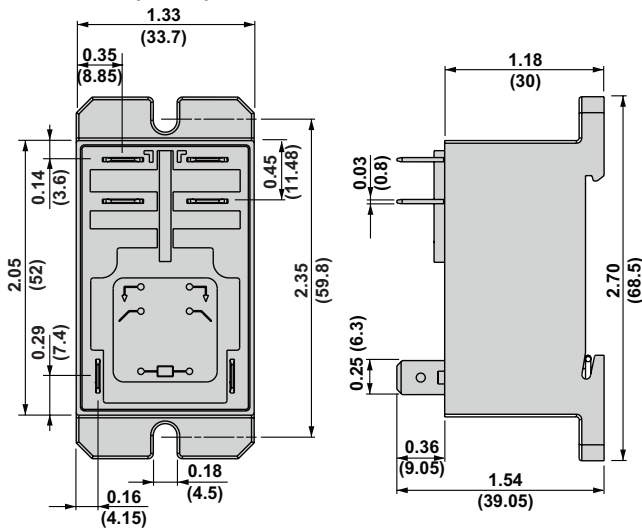

DPDT (2 CO):

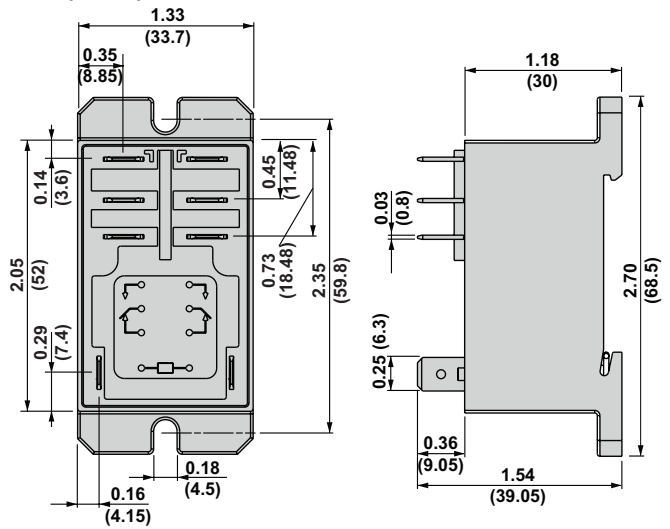

Wiring Diagrams

DPST-NO (2 NO):

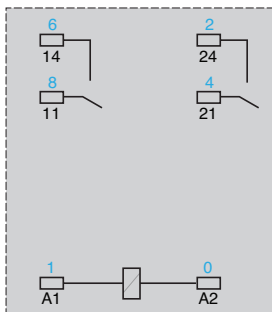

DPDT (2 CO):

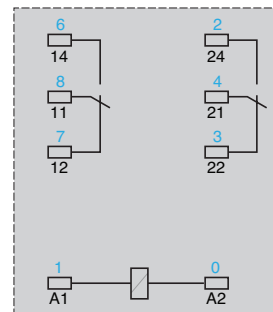

Description

Magnecraft Power Relays

9A

SPST-NO, 30 A;

SPDT, 30 A (NO) / 15 A (NC)

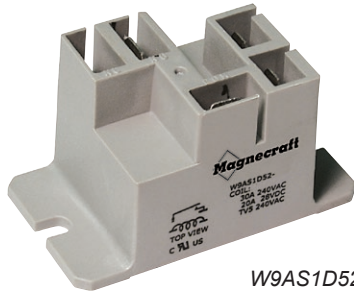

W9AS1D52

Description

The 9A series power relays offer robust performance in applications such as HVAC, motor controls, and alarm systems.

Feature	Benefit
Standard Class F insulation	Allows for maximum coil temperature of 155 °C (311 °F) which is ideal for high temperature applications
FLA/LRA and hp ratings	Capable of handling motor loads
Ballast load ratings	Suitable for lighting control applications
Small package size	Ideal for small spaces
Standard Quick Connect terminals	Simplifies and expedites installation

Rated Contact Current	Contact Configuration	Coil Voltage	Coil Resistance (Ω)	Standard Part Number
30 A	SPST-NO	24 Vac	500	9AS1A52-24
		120 Vac	3000	9AS1A52-120
		5 Vdc	25	9AS1D52-5
		12 Vdc	144	9AS1D52-12
		24 Vdc	576	9AS1D52-24
30 A (NO); 15 A (NC)	SPDT	24 Vac	500	9AS5A52-24
		120 Vac	3000	9AS5A52-120
		240 Vac	12100	9AS5A52-240
		5 Vdc	25	9AS5D52-5
		12 Vdc	144	9AS5D52-12
		24 Vdc	576	9AS5D52-24

Note: PC mount versions available, please call (847) 441-2540 for more information.

Part Number Explanation

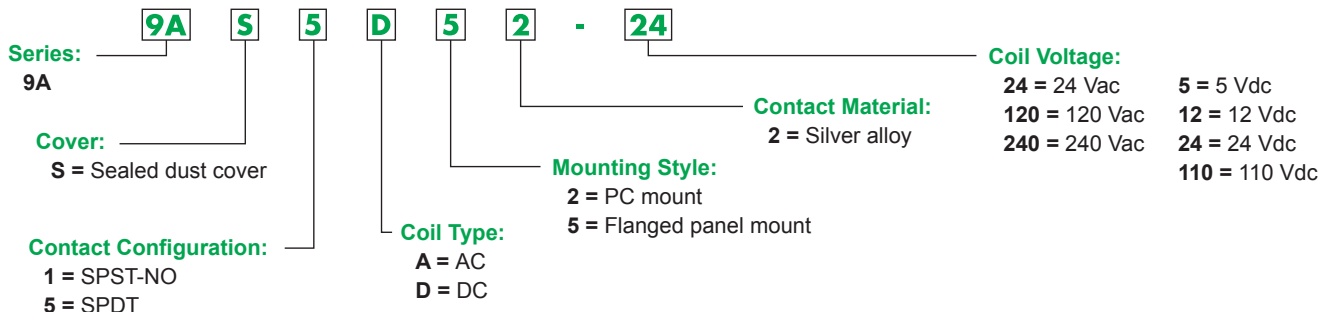

Specifications (UL 508)

Part Number	9AS1	9AS5
Contact Characteristics		
Contact Configuration	SPST-NO	SPDT
Contact Material	Silver Alloy	
Thermal (Carrying) Current	30 A	30 A (NO); 15 A (NC)
Maximum Switching Voltage	300 V	
Current Ratings at Voltage	<p>Resistive: 30 A at 240 Vac 50/60 Hz; 30 A at 28 Vdc, 100,000 cycles</p> <p>Motor: 1 hp at 125 Vac 50/60 Hz; 2 hp at 240 Vac 50/60 Hz, 1,000 cycles</p> <p>FLA/LRA: 22/98 A (NO) at 120 Vac 50/60 Hz, 30,000 cycles; 30/80 A (NO) at 240 Vac 50/60 Hz, 30,000 cycles</p> <p>Ballast: 10 A at 277 Vac, 6,000 cycles</p> <p>Pilot Duty: 470 VA, 6,000 cycles</p>	<p>Resistive: 30 A at 240 Vac 50/60 Hz (NO); 15 A at 240 Vac 50/60 Hz (NC); 30 A at 28 Vdc (NO); 10 A at 28 Vdc (NC), 100,000 cycles</p> <p>Motor: 1 hp at 125 Vac 50/60 Hz (NO); 1/4 hp at 125 Vac 50/60 Hz (NC); 2 hp at 240 Vac 50/60 Hz (NO); 1/2 hp at 240 Vac 50/60 Hz (NC), 1,000 cycles</p> <p>FLA/LRA: 22/98 A (NO) at 120 Vac 50/60 Hz, 30,000 cycles; 30/80 A (NO) at 240 Vac 50/60 Hz, 30,000 cycles; 12/30 A (NC) at 240 Vac 50/60 Hz, 30,000 cycles</p> <p>Ballast: 10 A at 277 Vac (NO); 3 A at 277 Vac (NC), 6,000 cycles</p> <p>Pilot Duty: 470 VA (NO), 275 VA (NC), 6,000 cycles</p>
Minimum Switching Requirement	100 mA at 12 Vac, 5 Vdc	
Coil Characteristics		
Coil Voltage Range ¹	24–240 Vac 50/60 Hz; 5–24 Vdc ¹	
Operating Range (% of Nominal)	80%–120% (AC); 75%–120% (DC)	
Average Consumption	2.8 VA (AC); 1 W (DC)	
Drop-out Voltage Threshold	10% (AC/DC)	
General Characteristics		
Electrical Life at Rated Load	100,000 cycles, unless otherwise specified under "Current Ratings at Voltage"	
Mechanical Life at No Load (Unpowered)	10,000,000 operations	
Operate Time at Nominal Coil Voltage	15 ms	
Dielectric Strength	Between coil and contact: 2500 Vac; Between contacts: 1500 Vac	
Operating Temperature Range	-40 – +55 °C (-40 – +131 °F)	
Storage Temperature Range	-40 – +85 °C (-40 – +185 °F)	
Vibration Resistance	3 g-n, 10–55 Hz	
Shock Resistance	10 g-n	
Weight (Average)	33 g (1.16 oz)	
Product Certifications	UL (E43641)	

Note: Actual product performance may vary depending on application and environmental conditions.

¹ For available standard coil voltages, please refer to the standard part number table on page 26.

Magnecraft Power Relays

9A
SPST-NO, 30 A;
SPDT, 30 A (NO) / 15 A (NC)

Dimensions — inches (millimeters)

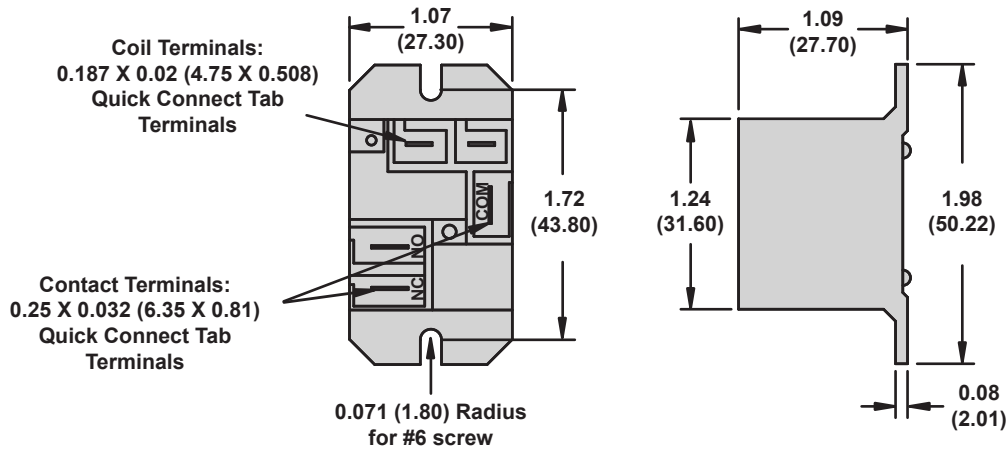

Wiring Diagrams

All diagrams are shown from top view

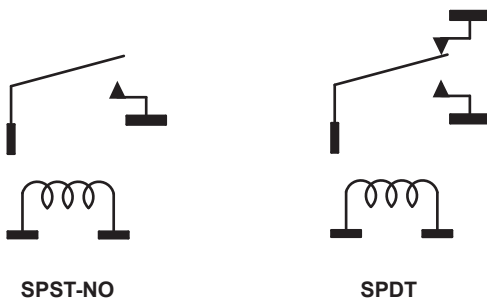

Magnecraft Power Relays

9A

DIN Rail Adapter, 16-9ADIN-1



Description

The 16-9ADIN-1 DIN rail adapter provides the mounting flexibility needed to mount the 9A Power Relay in a panel board or control box.

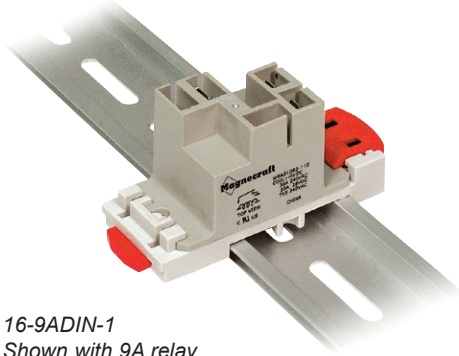

16-9ADIN-1
Shown with 9A relay

Description	Function	For Use With Relays	Packaging Minimum	Standard Part Number
DIN Rail Adapter	Enables the 9A relay to be mounted directly to a DIN rail	9A series relays	10	16-9ADIN-1

Dimensions — inches (millimeters)

